

Numerical Simulation and Physical Modeling as Educational Tools to Teach Metal Forming Processes

Sérgio Tonini Button

Abstract ³/₄ It is important to teach metal forming processes in undergraduate courses of Mechanical Engineering because they are widely used in the manufacturing industry. There is a great difficulty when teaching hot forging due to complex forging dies, high capacity presses, and billets at high temperatures. Numerical simulation does not provide a definitive response about the process because of the uncertainties about plastic behavior of the deformed material, and tribological conditions at the interface billet-dies. Physical modeling has been applied to validate numerical simulation results, because it involves low investments in equipment and tools and allows the analysis of metal flow.

Index Terms ³/₄ numerical simulation, physical modeling, education, hot forging.

I. INTRODUCTION

It is very important to teach metal forming processes in undergraduate courses of Mechanical Engineering because they are widely used to manufacture a great number of parts to industries like automotive, machine tools, hand tools, surgical instruments, and many others.

There is a great difficulty when teaching metal forming due to the large variety of processes, materials and products, which involve specific knowledge strongly related to craftsmen practical experience.

Lange [1] in chapter 2 classifies metal forming processes according with their specific stress states. In a first division five forming groups are defined: compressive, tensile, combined tensile and compressive, bending and shearing.

From these five main groups, seventeen sub-groups are defined as the primary processes, e.g. in the group of compressive forming: rolling, open die forging, close die forging, indenting and extrusion.

Each one of these seventeen sub-groups is divided again to describe the variations of each process. Lange defines these variations considering aspects like roll geometry, process kinematics and workpiece geometry.

Considering only geometrical aspects, seventy different processes are defined. Other conditions like workpiece material, product dimensions and work temperature could be

considered in the classification increasing the number of processes and making more evident the complexity of metal forming.

For example, the sub-group forging shows many variations with work temperature (hot, warm, cold, isothermal), open or closed dies (with flash or flashless), in hammers or presses, and compound processes like swaging and cross-rolling.

Another important reference in metal forming, Altan and Gegel [2], show a different classification with a first division related to the workpiece material: bulk forming processes (forging, rolling, extrusion and drawing) and sheet forming processes (stamping, deep drawing, bending and shearing).

Metal forming processes are so specific and show so many peculiarities that many books and handbooks were written to describe particular processes like in Laue and Stenger [3] (hot extrusion), Billigmann and Feldmann [4] (cold extrusion) and Metals Handbook [5] (forging).

To teach these processes it is necessary to associate theoretical knowledge about mechanical and metallurgical aspects with practical information about these processes to guarantee process viability and products quality.

II. NUMERICAL SIMULATION OF METAL FORMING

Hot forging is a widely used manufacturing process mainly for its minimum waste and dimensional precision, and it usually improves the mechanical properties of the formed part. However, the forming sequence of a new design is not a straightforward task, and it requires many trials and adjustments to achieve satisfactory production conditions. The empirical "trial and error" method has been traditionally applied to metal forming design; however, this approach is expensive and time consuming.

Computer simulation has become reliable and acceptable in the metal forming industry since the 1980's. Metal forming analysis can be performed in three modeling scales [6]. The first scale is the global modeling, which only predicts process loads or work. Analytical methods are used for this purpose. Local scale analysis is used to estimate the thermomechanical variables such as strain, strain rate, and temperature.

With the extensive development in computational mechanics, numerical methods have been used as an economical alternative to perform the local modeling. Micro-scale modeling computes the micro-structural evolution during the forming process. Since global scale analysis is only applicable to simple situations and micro modeling is

still incipient and only gives results for specific conditions, local modeling is the most popular approach. Among other methods, the Finite Element Methods (FEM) is widely used in metal forming analysis due to its capabilities to model the complicated shapes of tools and parts in forming processes.

In this paper, we present the simulation results of the hot forging of an automotive transmission gear. The commercial finite element software ANSYS [7] was used. The contact conditions were modeled by the Coulomb law and the multilinear elasto-plastic material model is used.

Fig. 1 shows the simulated evolution of the blocking operation and a filling defect.

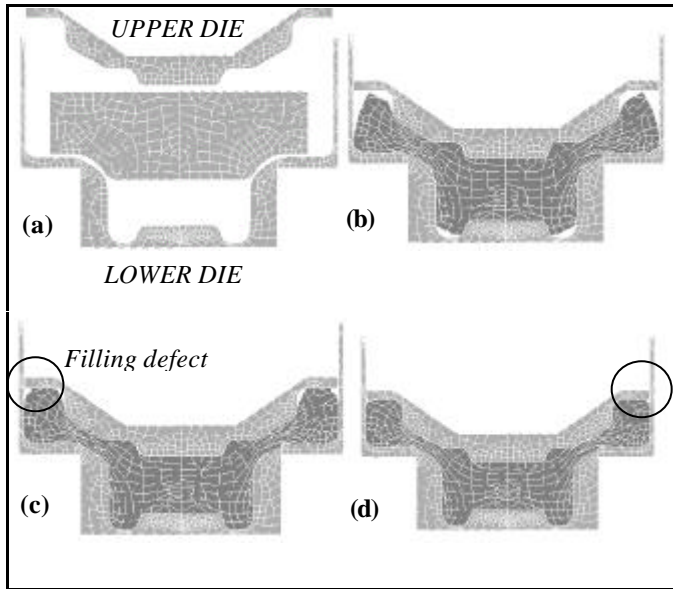

Fig. 1 - Simulated evolution of the blocking operation.

III. PHYSICAL MODELING AS AN EDUCATIONAL TOOL

Johnson [8] states that experimental work used to teach metal forming shows an important feature when we analyze the great development observed in the numerical simulation of processes, mainly the finite element method. The increasing capacity of these methods and commercial software must be accompanied by a consistent practical learning which will allow the manufacturing engineer to provide the correct pre-processing information (initial conditions of temperature, speed and friction, and workpiece material properties) and to analyze the simulation results (strain, stress and temperature distributions in the products and tools) to predict and prevent process problems like defects in the products or tools damage.

Numerical simulation does not provide itself a definitive response about the process analyzed because of the uncertainties related to the plastic behavior of the deformed material, and to the tribological conditions in the interface workpiece-dies. Physical modeling has been applied to validate numerical simulation results, because it involves low investments in equipment and tools and allows the analysis of metal flow preventing forging defects [9]-[12].

Lead and plasticine have been used as modeling materials with interesting results. They are cheap and present flow behavior similar to hot forged metallic alloys, and allow the analysis of the correct filling of dies which will provide quality products [13]. Fig. 2 [14] shows the flow similarity of two modeling materials forged at room temperature when compared to aluminum forged at 400 °C.

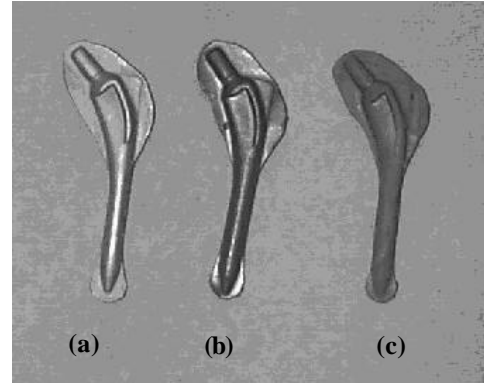

Fig. 2 – Forged femoral stems: (a) aluminum, (b) lead, and (c) plasticine.

Physical modeling has shown an important use in industry as presented in Fig. 3 [15], which shows the simulation of the hot forging of steel crankshafts with the forging of plasticine at room temperature with synthetic resin dies (a). It is possible to observe the incorrect filling of the dies (b) and consequently define the most appropriate preform with low costs and reduced analysis time.

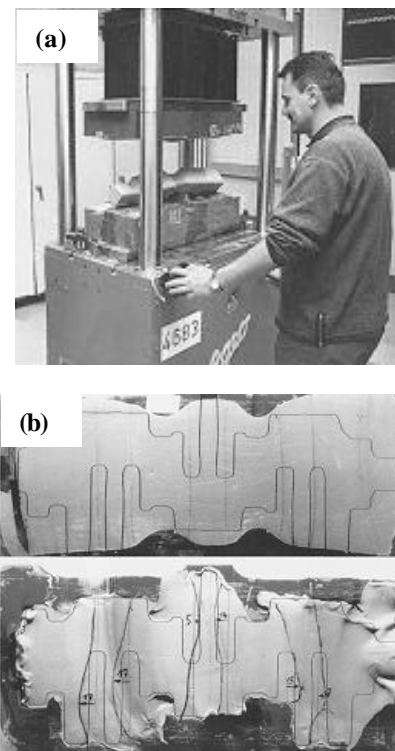

Fig.2 – (a) physical modeling of crankshafts hot forging (b) flow of the plasticine in the forging dies

IV. PHYSICAL MODELING EXPERIMENTS AT THE METAL FORMING LABORATORY

The students' activities at the metal forming laboratory in the forging experiments are described below.

A. Objectives

With the drawings of an automotive part, students must design the forged part and the forging dies. The dies are manufactured with an epoxy resin from forging models made of wax, wood or nylon.

Forging tests were carried out to study the influence of the preform on the flow of the workpiece, on the product quality, and in some cases, on the reduction of the flash. These tests also demonstrate the importance of modeling materials, like the plasticine, in the simulation of metal forming processes.

B. Experimental Methods and Materials

Groups of five students receive drawings of parts commonly used in mechanical systems (gears, connecting rods, wheels and axles) like the spur gear shown in Fig. 4.a. The students also receive the materials necessary to manufacture the models, the dies, and the preforms.

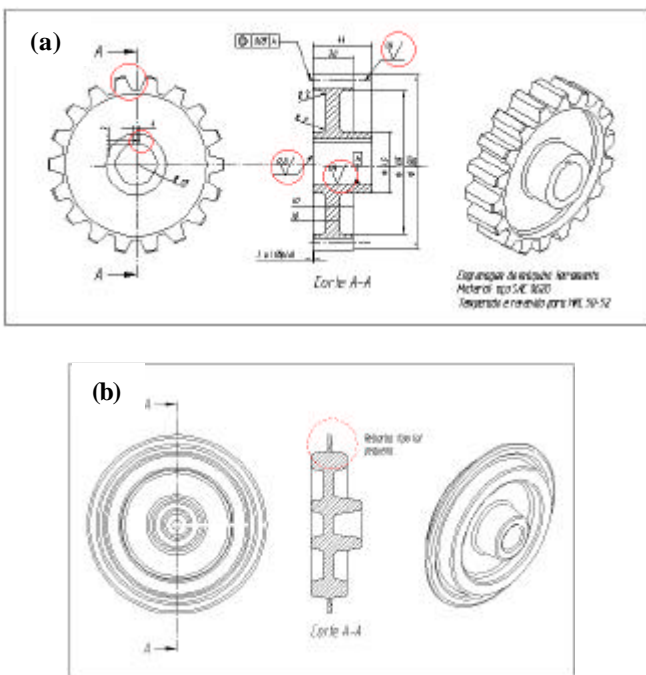

Fig. 4 – (a) Spur gear drawings and dimensions
(b) hot forged spur gear.

With design criteria commonly used in the industry, the students design the forgings (Fig. 4.b) and the forging dies (Fig. 5), defining their shape, dimensions, and surfaces to position and guide the workpiece.

The next step is the manufacturing of the forging model, in wood for axisymmetric shapes whose are easy to machine by turning, or in wax for more complex shapes. Nylon and epoxy

are other possible materials. The dies are manufactured molding layers of epoxy on the forging model. Fig. 6 shows two models and Fig. 7 shows some dies made by the students.

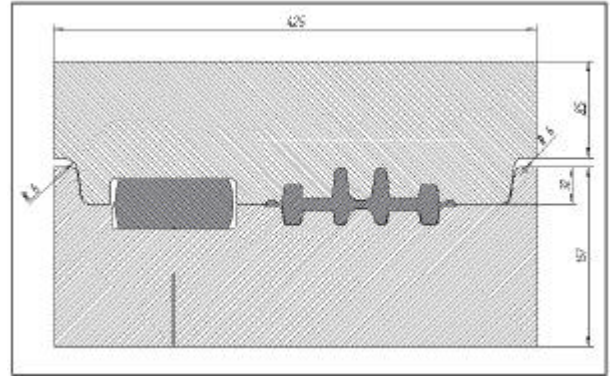

Fig. 5 – Forging dies.

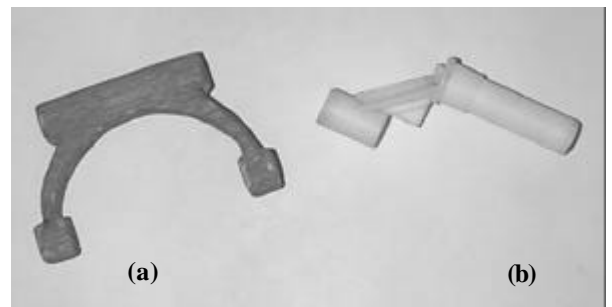
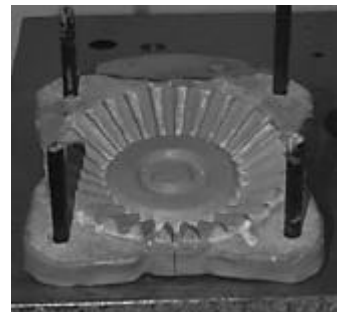

Fig. 6 – Two models of forgings:
(a) transmission shifter fork in wood
(b) motor cycle pedal crank in nylon.



(a)



(b)

Fig.7 – Forging dies in epoxy:
(a) bevel gear,
(b) transmission shifter fork.

The volume of the forgings are calculated from the models including the flash. With this volume the students prepare preforms of many shapes to test which would provide the best filling of the dies avoiding defects in the products.

Many coloured layers of plasticine form the preforms to help the observation of the material flow and strain distribution in the forgings. The plasticine is previously mixed with powder gypsum to properly represent the plastic behaviour of metallic alloys when hot forged [16].

The forging tests are carried out in a hydraulic press using PVC films as lubricant in the interface dies-preform.

V. RESULTS AND DISCUSSION

The forging test is halted during the upper die stroke to analyse the material flow. After the forging test of each preform the forging quality is analysed to observe possible surface defects or improper flash lands. If necessary, another preform is molded, tested and analysed.

Plasticine forgings are cut off in their longitudinal planes to analysis the flow lines and to observe and prevent internal defects.

Fig. 8 shows some forgings from these tests. Forging (a) related to the die in Fig. 6.a shows the teeth correctly formed; the flow was almost axisymmetric and the dies were completely filled. This flashless forging is an important example of near-net-shape manufacturing .

Forging (b) related to the model of Fig. 6.b and to the die of Fig. 7.b, shows how the flash can be minimized with a proper preform. In this case the flash can not be eliminated due to the predominant lateral flow of the material.

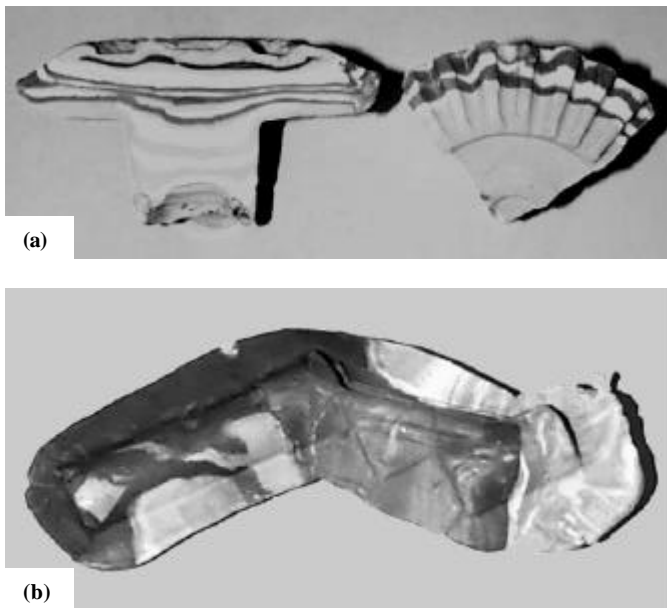

Fig. 8 – Plasticine forgings: (a) bevel gear; (b) motor cycle pedal crank.

VI. CONCLUSION

Physical modeling of metal forming processes is an useful tool to process optimization since experimental results can be compared to the numerical simulation results. It is an interesting and cheap method to aid the practical education of undergraduate students.

Because this work is being developed just for the last ten months, we observed that the techniques to mold models and dies manufacturing must be improved.

REFERENCES

- [1] K. Lange (Editor), *Handbook of Metal Forming*, McGraw-Hill Book Co., 1985.
- [2] T. Altan, S.I. Oh and H.L. Gegel, *Metal Forming, Fundamentals and Applications*, American Society for Metals, Metals Park, Ohio,USA, 1.983.
- [3] K. Laue and H. Stenger, *Extrusion, Processes, Machinery, Tooling*, American Society for Metals, Metals Park, Ohio,USA, 1981.
- [4] J. Billigmann and H.D. Feldmann, *Estampado y Prensado a Máquina*, Editorial Reverté S.A., Barcelona, 1979.
- [5] Metals Handbook, *Forging*, vol. 14, 9th ed., ASM International, Metals Park, Ohio,USA, 1989.
- [6] R. Kopp, M.L. Cao and M.M. Souza, "Multi-level simulation of metal forming process", *Proc. 2nd ITCP*, Stuttgart, August 1987, pp. 1128-1234.
- [7] ANSYS User's Manual for Rev. 5.4, v. III - *Elements Manual*, 1995.
- [8] W. Johnson, "Developments in forming technology – an engineering educator's approach", *Journal of Materials Processing Technology*, vol. 31, pp. 1-26, 1992.
- [9] T. Altan and M. Ahmetoglu , "Special issue: selected papers on sheet forming and stamping and forging and machining, from the Engineering Research Center for Net Shape Manufacturing, The Ohio State University, Columbus, Preface", *Journal of Materials Processing Technology*, vol. 59, ns. 1 e 2, 1996.
- [10] S. Fujikawa, "Application of CAE for hot-forging of automotive components", *Journal of Materials Processing Technology*, Vol. 98, n. 2, pp. 176-181, 2000.
- [11] H. Yoshimura and K. Tanaka, "Precision Forging of Aluminum and Steel", *Journal of Materials Processing Technology*, Vol. 98, n. 2, pp. 196-204, 2000.
- [12] Y.H. Moon and C.J. Van Tyne, "Validation via FEM and plasticine modeling of upper bound criteria of a process-induced side-surface defect in forgings", *Journal of Materials Processing Technology*, Vol. 99, pp. 185-196, 2000.
- [13] A.E.M. Pertence and P.R. Cetlin, "Analysis of a new model material for the physical simulation of metal forming", *J. of Materials Processing Technology*, vol. 84, pp. 261-267, 1998.
- [14] S.T. Button, "O ensino em laboratório de processos de conformação plástica de metais", *Anais do XV Congresso Brasileiro de Engenharia Mecânica*, Águas de Lindóia, SP, Brasil, CD-ROM, 1999.
- [15] J. Haats, "Lightweight crankshaft drives using forged components, *Forum – Technische Mitteilungen ThyssenKrupp*, English Edition, Thyssen Krupp AG, p. 54-55, 1999.
- [16] V. Vazquez and T. Altan, "New concepts in die design - physical and computer modeling applications", *Journal of Materials Processing Technology*, Vol. 98, n. 2, pp. 212-223, 2000.